

Case Study Competition 2009

Ready for take-off!

The future of air-traffic control is in your hands

Final round exercises



ROHDE & SCHWARZ

Scenario

- You are a designer of radiocommunications systems for civil and military air-traffic control.
- Your latest customer was impressed by your proposals for expanding an existing radio system and intends to award you a major contract for expanding all of the customer's radio stations.
- Implementation of this project starts with a definition phase, during which you analyze all requirements that are relevant to the customer and develop concepts suitable to fulfill these requirements.
- The final step in the definition phase is the Preliminary Design Review (PDR), in which you present your concepts to the customer.
- If the customer approves the proposed concepts, i.e. if the PDR is successfully passed, you can continue with the project as planned.

Introduction – general information on how to proceed

The customer intends to expand existing radiocommunications systems by adding new radios and new waveforms.

Among other things, the following methods are to be included:

- Orthogonal Frequency Division Multiplex (OFDM) multicarrier method for wireless Internet.
- Frequency-hopping method, i.e. a method capable of rapid frequency changes during operation.

In implementing the project, various criteria have to be considered, for example:

- There are limitations regarding heat dissipation in the system racks.
- All radio links should be capable of operating simultaneously without any link affecting any other.

Procedure:

- First, specific components (e.g. transmitters, filters, couplers) are examined to determine their relevant characteristics.
- Second, the components in question are combined to yield a suitable system.
- Finally, the system is optimized where necessary.

Analysis of individual components

Exercise 1 – Basic assumptions, part 1

To estimate the dissipated power of a transmitter, a simple operational model is used:

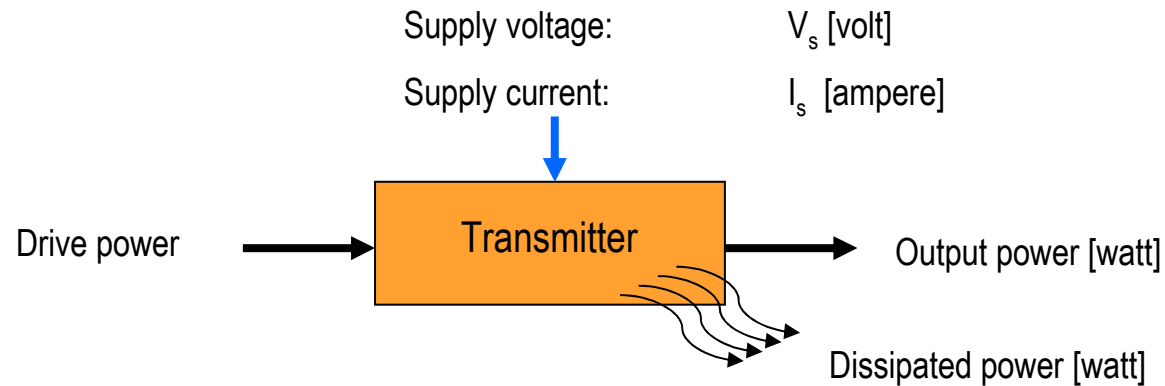

For the purpose of this analysis, it is assumed that transmitters are characterized by the following parameters:

P_{\max} : maximum possible peak output power in watt

η : efficiency = output power / supplied power (considerably simplified model)

η_{\max} : efficiency during operation at maximum possible peak output power P_{\max}

I_{\max} : current consumption during operation at maximum possible peak output power P_{\max}

I_{av} : current consumption during operation at a defined average output power P_{av}

I_{av} is obtained as follows: $I_{\text{av}} = I_{\max} * \sqrt{(P_{\text{av}} / P_{\max})}$ (considerably simplified model)

Analysis of individual components

Exercise 1 – Basic assumptions, part 2: Dissipated power of an OFDM transmitter

The task is to determine the dissipated power of a transmitter when it is operated with a specific modulation mode.

In the exercises below, two transmitters of different type are to be operated in the following mode:

Orthogonal Frequency Division Multiplex (OFDM), which is a multicarrier method. A special characteristic of this method is that its instantaneous power may vary strongly.

- Modulation mode: OFDM
- Peak-to-Average Power Ratio (PAPR): 10 dB *1)
- Frequency range: 225 MHz to 400 MHz
- Occupied channel bandwidth: 5 MHz

*1) PAPR is the ratio of the maximum short-duration peak power and the power averaged over an extended period of time.

Analysis of individual components

Exercise 1.1 (6 points) – Dissipated power of a type A (medium power) OFDM transmitter

A transmitter with the following characteristics is assumed (see "Basic assumptions, part 1"):

P_{\max} :	100 W
Supply voltage V_s :	28 V
η_{\max} :	35 %

- 1 Calculate the current I_s if the transmitter is operated unmodulated at maximum possible peak output power (2 points).
- 1 Calculate the current I_{av} if the transmitter is operated with OFDM modulation and its maximum peak output power equals the maximum possible peak output power P_{\max} (2 points).
- 1 What is the power dissipated as heat in the second case (2 points)?

Analysis of individual components

Exercise 1.1 (8 points) – Dissipated power of a type B (high power) OFDM transmitter

To improve linearity in OFDM mode, it may be necessary to operate the transmitter not at full output power. It is therefore meaningful to consider the following cases as well:

- Calculate the current I_s if the transmitter output power is reduced by **3 dB** (2 points).
- What is the power dissipated as heat in this case (2 points)?
- Calculate the current I_s if the transmitter output power is reduced by **6 dB** (2 points).
- What is the power dissipated as heat in this case (2 points)?

Analysis of individual components

Exercise 1.2 (6 points) – Dissipated power of a type B (high power) OFDM transmitter

A transmitter with the following characteristics is assumed (see "Basic assumptions, part 1"):

P_{\max} :	400 W
Supply voltage V_s :	28 V
η_{\max} :	40 %

- 1 Calculate the current I_s if the transmitter is operated unmodulated at maximum possible peak output power (2 points).
- 1 Calculate the current I_{av} if the transmitter is operated with OFDM modulation and its maximum peak output power equals the maximum possible peak output power P_{\max} (2 points).
- 1 What is the power dissipated as heat in this case (2 points)?

Analysis of individual components

Exercise 1.2 (8 points) – Dissipated power of a type B (high power) OFDM transmitter

To improve linearity in OFDM mode, it may be necessary to operate the transmitter not at full output power. It is therefore meaningful to consider the following cases as well:

- Calculate the current I_s if the transmitter output power is reduced by **3 dB** (2 points).
- What is the power dissipated as heat in this case (2 points)?
- Calculate the current I_s if the transmitter output power is reduced by **6 dB** (2 points).
- What is the power dissipated as heat in this case (2 points)?

Analysis of individual components

Exercise 1 – Basic assumptions, part 3: Dissipated power of a transmitter in frequency-hopping mode

Next, the dissipated power is to be determined for the two transmitter types (A and B) using a completely different operating mode.

In the exercises below, the following operating mode is to be used:

Frequency hopping *1)

- Modulation mode: FM
- Time required for a frequency change: 0.5 ms (Note: The transmitter is switched off during this time.)
- Dwell time for each frequency: 2 ms
- Frequency range: 225 MHz to 400 MHz
- Occupied channel bandwidth: 25 kHz

*1) Note:

- The transmitter transmits for 2 ms at frequency F1 at an occupied channel bandwidth of 25 kHz.
- The transmitter is then switched off for a period of 0.5 ms (current consumption = 0 A). During this time, the transmitter is switched to frequency F2.
- The transmitter then transmits for 2 ms at frequency F2.

Analysis of individual components

Exercise 1.3 (3 points) – Dissipated power of a type A (medium power) frequency-hopping transmitter

A transmitter with the following characteristics is assumed (see "Basic assumptions, part 1,, and also part 3):

P_{\max} :	100 W
Supply voltage V_s :	28 V
η_{\max} :	35 %

- Calculate the peak current I_s if the transmitter is operated at maximum possible peak output power in frequency-hopping mode (1 point).
- What is the average power dissipated as heat in this case (2 points)?

Analysis of individual components

Exercise 1.4 (3 points) – Dissipated power of a type B (high power) frequency-hopping transmitter

A transmitter with the following characteristics is assumed (see "Basic assumptions, part 1" and also part 3):

P_{\max} :	400 W
Supply voltage V_s :	28 V
η_{\max} :	40 %

- Calculate the peak current I_s if the transmitter is operated at maximum possible peak output power in frequency-hopping mode (1 point).
- What is the average power dissipated as heat in this case (2 points)?

Analysis of individual components

Exercise 2.1 (3 points) – Suitability of filters / bandpass filters

Bandpass filters with the following characteristics are available:

Filter type 1		Filter type 2	
Frequency range	225 MHz to 400 MHz	Frequency range	225 MHz to 400 MHz
Passband bandwidth	500 kHz	Passband bandwidth	100 kHz
Tuning time F1 → F2	1 s	Tuning time F1 → F2	0.3 ms

- Which of the two filters is suitable for operation in frequency-hopping mode (see [Exercise 1](#)) ([1 point](#))?
- Name at least two criteria relevant to selecting one of the two filters ([2 points](#))?

Analysis of individual components

Exercise 2.2 – Part 1: Suitability of filters / bandpass filters for use in a combiner circuit

Bandpass filters can be used to build a filter coupler (= combiner). This is done by connecting the filters in parallel in a star point. Up to four transceivers can be combined using a configuration of this type.

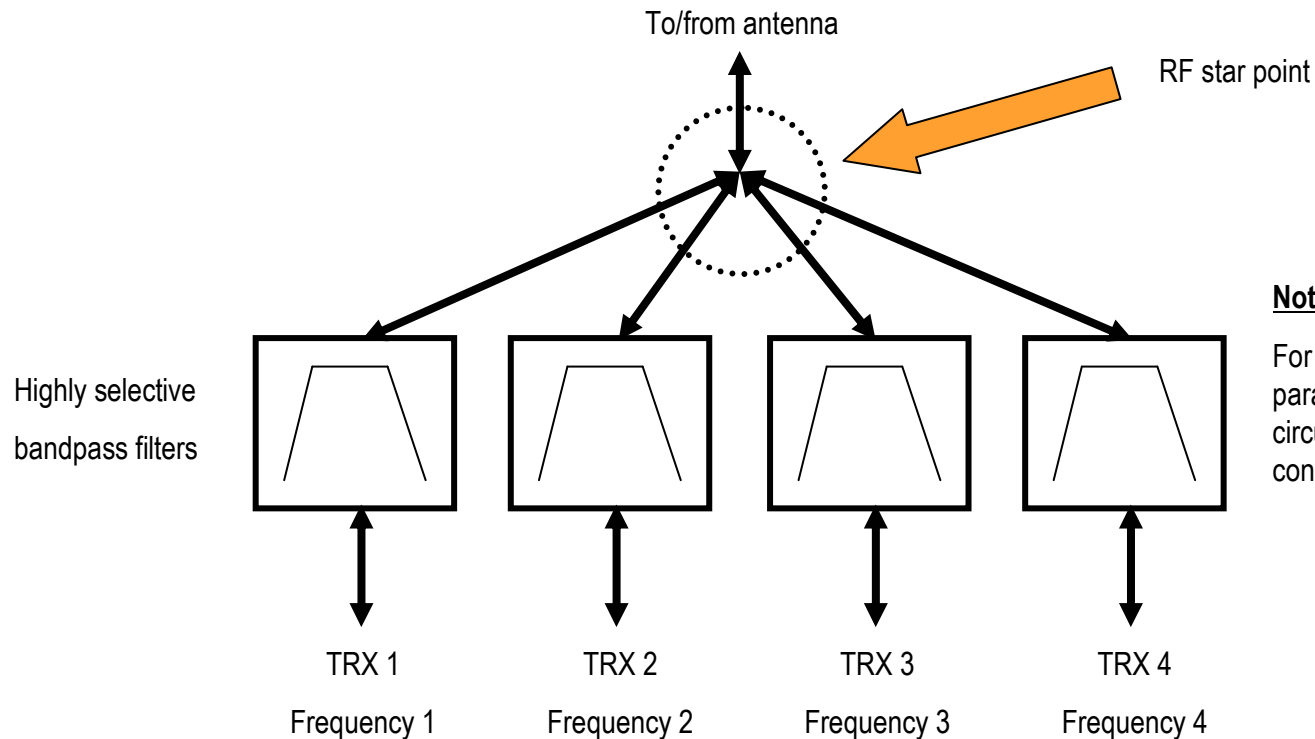

Note:

For the configuration shown here, an ideal parallel circuit can be assumed, i.e. a circuit where the star point does not contribute to the insertion loss.

TRX = transceiver (transmitter + receiver combined in one unit)

Analysis of individual components

Exercise 2.2 – Part 2 (3 points): Suitability of filters / bandpass filters for use in a combiner circuit

The individual filters, which may be of type 1 or type 2, should have the following typical selectivity characteristics:

- Insertion loss 2 dB
- Selectivity as shown in diagram (referenced to insertion loss)

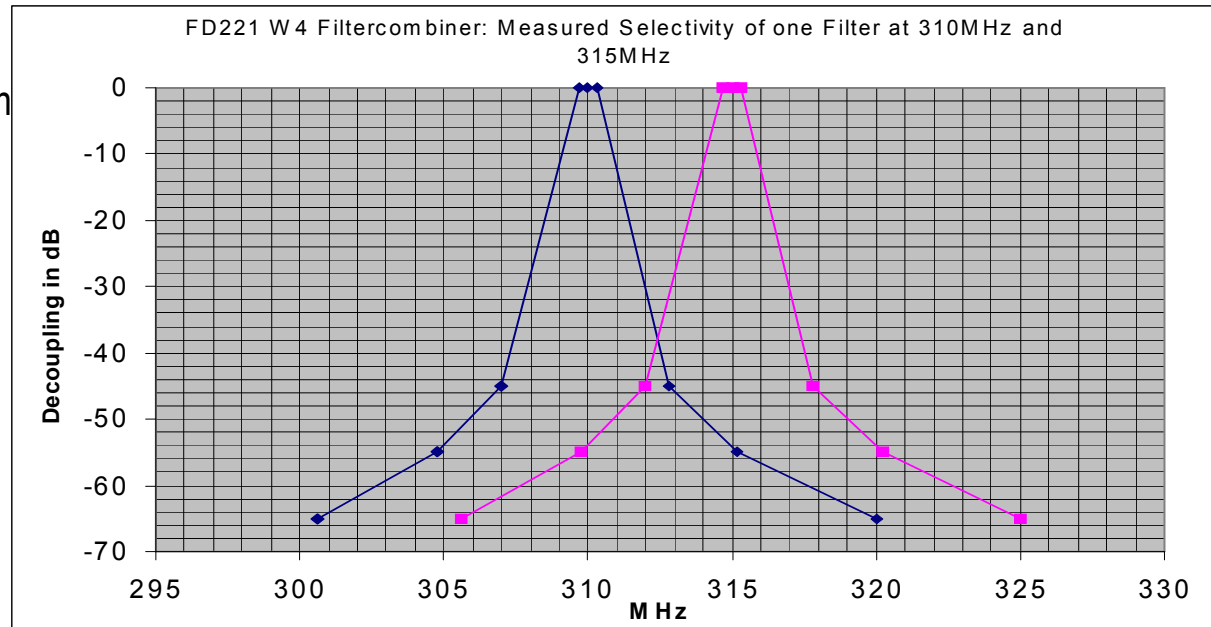

- How can the decoupling between two transceivers be determined from the above data, if one transceiver is operating at **310 MHz** and the other at **315 MHz** (2 points)?
- What will happen if two filters operate at the same frequency (1 point)?

Analysis of individual components

Exercise 2.3 (1 point) – Suitability of filters / diplexers

A diplexer with the following characteristics is assumed:

Insertion loss: 0.5 dB

Stopband attenuation: 60 dB

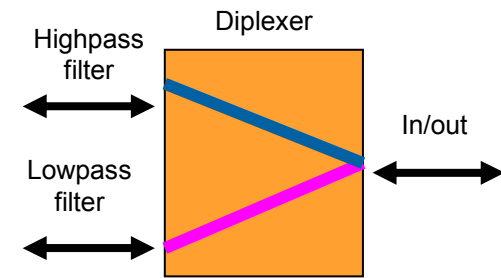
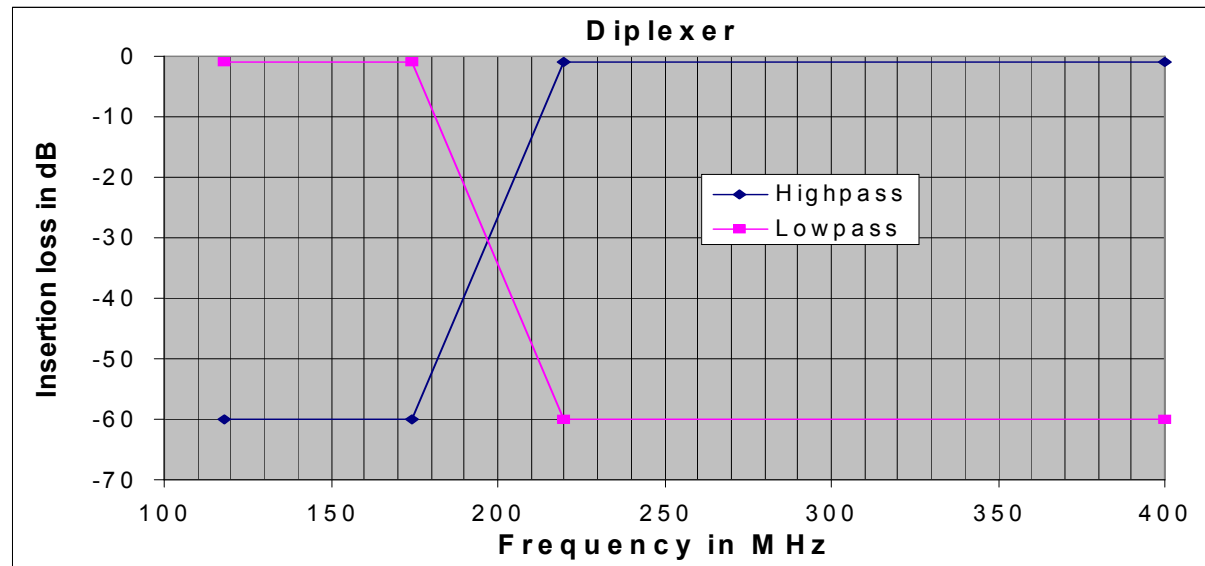

- Can the diplexer with the above characteristics be used for operation in OFDM mode (1 point)?

System expansion

Exercise 3 – Basic assumptions, part 1: Customer system

The customer already has a radiocommunications system in operation, and your job is to expand it.
The system is characterized by the data shown below and is currently used for voice communications only.

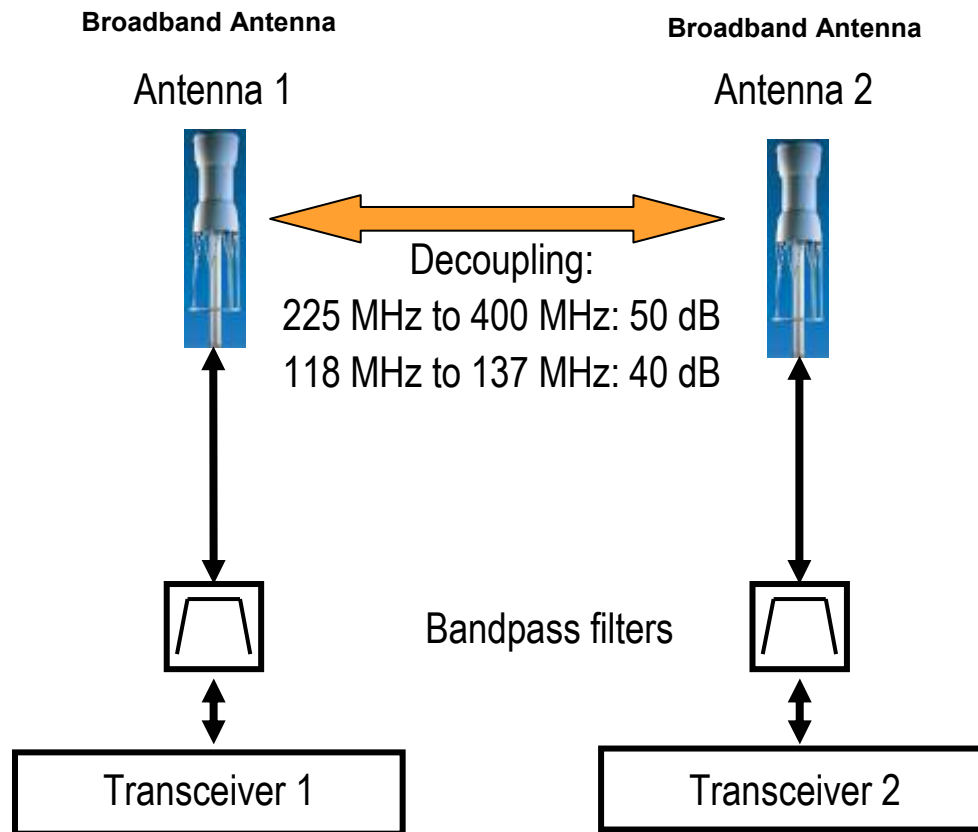

The components for the two links have the following data:

Transceiver

Frequency range	118 MHz to 137 MHz
Transmit power (carrier)	30 W
Transmitter noise floor	-160 dBc/Hz
Receiver sensitivity (AM, m = 0.3)	-105 dBm
Permissible interference level at receiver	0 dBm
Dissipated power	300 W (transmission) 30 W (reception)

Antenna gain 0 dBd

Bandpass filter

Frequency range	118 MHz to 137 MHz
Insertion loss	2 dB

Cable losses are to be neglected.

System expansion

Exercise 3.1 (5 points) – Customer system / Analysis of existing system

The system described above is to be analyzed. Cable losses are to be neglected.

- What is the sensitivity at the base of each antenna (1 point)?
- What transmit power (carrier power) is present at each antenna (1 point)?
- What is the maximum interference level at the base of each antenna (caused by the transmitter of the respective other path) if each transmitter is operated with AM, $m = 100\%$ (1 point)?
- What is the main purpose fulfilled by the two bandpass filters in the system (1 point)?
- Are there any limitations or constraints regarding the simultaneous operation of the two transceivers (1 point)?

System expansion

Exercise 3 – Basic assumptions, part 2: Customer system

The following functions are to be added to the existing customer system:

Two radio links with the following characteristics:

Method:	frequency hopping method as used in Exercise 1
Frequency range:	225 MHz to 400 MHz
Application:	voice communications
Transmit power at the antenna:	$\geq 20 \text{ W}$
Sensitivity at the antenna:	$\leq -104 \text{ dBm}$

One radio link with the following characteristics :

Method:	OFDM method as used in Exercise 1
Frequency range:	225 MHz to 400 MHz
Application:	data communications
Transmit power at the antenna:	$\geq 4 \text{ W}$ average
Sensitivity at the antenna:	$\leq -80 \text{ dBm}$

Minimum performance data to be maintained for the *existing* system components:

Transmit power at the antenna:	$\geq 10 \text{ W}$ (carrier)
Sensitivity at the antenna:	$\leq -100 \text{ dBm}$ (AM, $m = 0.3$)

System expansion

Exercise 3 – Basic assumptions, part 3: Customer system

The following components are available for expanding the customer system:

Radio 1:

Method:	frequency hopping method as used in Exercise 1
Frequency range:	225 MHz to 400 MHz
Application:	voice communications
Transmit power:	100 W
Sensitivity:	-110 dBm
Dissipated power:	300 W (transmission), 30 W (reception)
Price:	€50,000

Radio 2:

Method:	OFDM method as used in Exercise 1
Frequency range:	225 MHz to 400 MHz
Application:	data communications
Transmit power:	200 W peak power
Sensitivity:	-90 dBm
Dissipated power:	500 W (transmission), 50 W (reception)
Price:	€20,000

System expansion

Exercise 3 – Basic assumptions, part 4: Customer system

The following further components are available for system expansion:

Filter combiner consisting of up to four bandpass filters:

The following filter types are available for creating a filter combiner. The filter types can be combined in any desired way.

Filter type 1		Filter type 2	
Frequency range	225 MHz to 400 MHz	Frequency range	225 MHz to 400 MHz
Passband bandwidth	500 kHz	Passband bandwidth	100 kHz
Tuning time F1 → F2	1 s	Tuning time F1 → F2	0.3 ms
Price	€5,000	Price	€50,000

Diplexer with the following characteristics:

Insertion loss: 0.5 dB

Stopband attenuation: 60 dB

Price: €500 (for frequency response, see [Exercise 2.3](#))

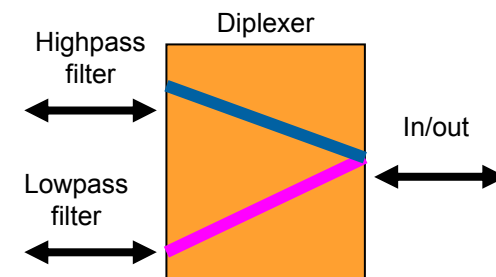

System expansion

Exercise 3 – Basic assumptions, part 5: Customer system

The following further components are available for system expansion:

Attenuators with different attenuation values:

The following attenuators are available:

Attenuator:	3 dB	6 dB	10 dB
	Price: €500	Price: €1,000	Price: €2,000

System expansion

Exercise 3.2 – Expansion of existing system: Procedure and basic assumptions and requirements

- The customer system presented on page 17 is to be expanded.
- The basic assumptions and requirements as well as the available components and radios are stated on the previous pages.

Additional requirements:

- A minimum decoupling of **55 dB** must be attained between all transmitters and all receivers.
- The antenna configuration with a given decoupling must not be changed.
- The system may otherwise be changed at any desired points at one or both antenna locations.
- If bandpass filters are used, any operational conditions or requirements to be fulfilled in order to attain the required decoupling must be stated.
- If cables are used, the cable losses are to be neglected.

Note:

- The market sometimes offers a broader range of products than needed to implement a system.
- It may happen, therefore, that not all of the components available are actually necessary.

System expansion

Exercise 3.2 (15 points) – Expansion of existing system

- Create a block diagram of the expanded system including all essential components and radios and complying with the specified basic assumptions and requirements (12 points).
- What transmit power (carrier power) (at the antenna base) is achieved by the components of the existing system, i.e. the system prior to the expansion (1 point)?
- What sensitivity (at the antenna base) is achieved by the components of the existing system, i.e. the system prior to the expansion (1 point)?
- Can all radio links be operated simultaneously and independently of one another, or are there any operational requirements or constraints (1 point)?

System expansion

Exercise 3.3 (2 points) – Analysis and optimization of expanded system

- The expanded system includes radios used exclusively for voice communications and radios used exclusively for data communications. An important difference between the two operating modes is the ratio of transmission time to reception time and the resulting amount of dissipated power.
- The average ratio of transmission time to reception time is expressed as the duty cycle.
- The following duty cycles are specified for the expanded system:
 - Voice communications: duty cycle of **1:5**, i.e. 1 time unit of transmission followed by 5 time units of reception
 - Data communications: duty cycle of **1:1**, i.e. 1 time unit of transmission followed by 1 time unit of reception
- Based on the above data, calculate the average dissipated power of a voice communications radio (1 point).
- Based on the above data, calculate the average dissipated power of a data communications radio (1 point).

System expansion

Exercise 3.4 (5 points) – Analysis and optimization of expanded system

- Create a list of materials that includes only the newly added components and radios for the system expansion. The list must clearly specify the type, required number of items and price for each component and radio (2 points).

The customer finds the system expansion quite appealing in terms of technical performance, but objects that targeted budgetary limits are exceeded. The customer therefore wishes to replace one of the two frequency-hopping radios by a more favorably priced version that can operate in fixed-frequency mode only. The customer accepts a frequency change to take up to 2 seconds.

- What modification(s) would you make to the system in order to meet the above customer requirement at optimized costs (2 points)?
- By which amount can the price for the system expansion be reduced through this measure if the simplified radio version alone costs €10,000 less than the originally intended version (1 point)?

Get ready for take-off, and lots of luck!

- **Each exercise can normally be solved independently of the preceding one.**
- **Most of the exercises do not require complex calculations. The best approach is by clear and logical consideration.**
- **Please note that, while a large amount of information and data is given, not all of the data and components may be needed in each case.**

We hope you enjoy solving the exercises in this final round and wish you good luck with them.